

dddrop



Handleiding Dimafix Pen

NEDERLANDS

Oorspronkelijke gebruiksaanwijzing

In deze handleiding wordt kort uitgelegd hoe de Dimafix Pen het beste gebruikt kan worden met dddrop 3D Printers met een glazen printbed. Dimafix zorgt voor een goede hechting tussen de glasplaat en het kunststof en geeft een beschermende laag aan de glasplaat.

Stap 1

Schud de Dimafix Pen goed voor gebruik.



Stap 2

Smeer Dimafix op de (koude) glasplaat. Laat dit goed opdrogen voordat er een print gestart wordt. De Dimafix begint te werken bij een temperatuur boven de 65°C.



Stap 3

Na het printen: Laat de glasplaat goed afkoelen voordat het geprinte 3D model van de glasplaat afgehaald wordt. Als Dimafix warm is, dan hecht het model erg goed. Afgekoeld zorgt ervoor dat het model makkelijker los laat.

Stap 4

Om Dimafix te verwijderen van de glasplaat, gebruik hiervoor **NOOIT** schoonmaakmiddelen! Alleen schoonmaken met een zachte doek en water.

Op de volgende pagina's is de technische datasheet van Dimafix bijgevoegd.

Bronvermelding: <http://www.dima3d.com/en/our-products/#dimafix>



Technical Specifications

Dimafix® is a smart adhesive that varies its adherence properties according to the temperature, in the range usually used for 3D printing. Figure 1 shows how Dimafix® increases adherence as the printing bed is heated in a test performed using ABS and a regular flat glass hot-bed.

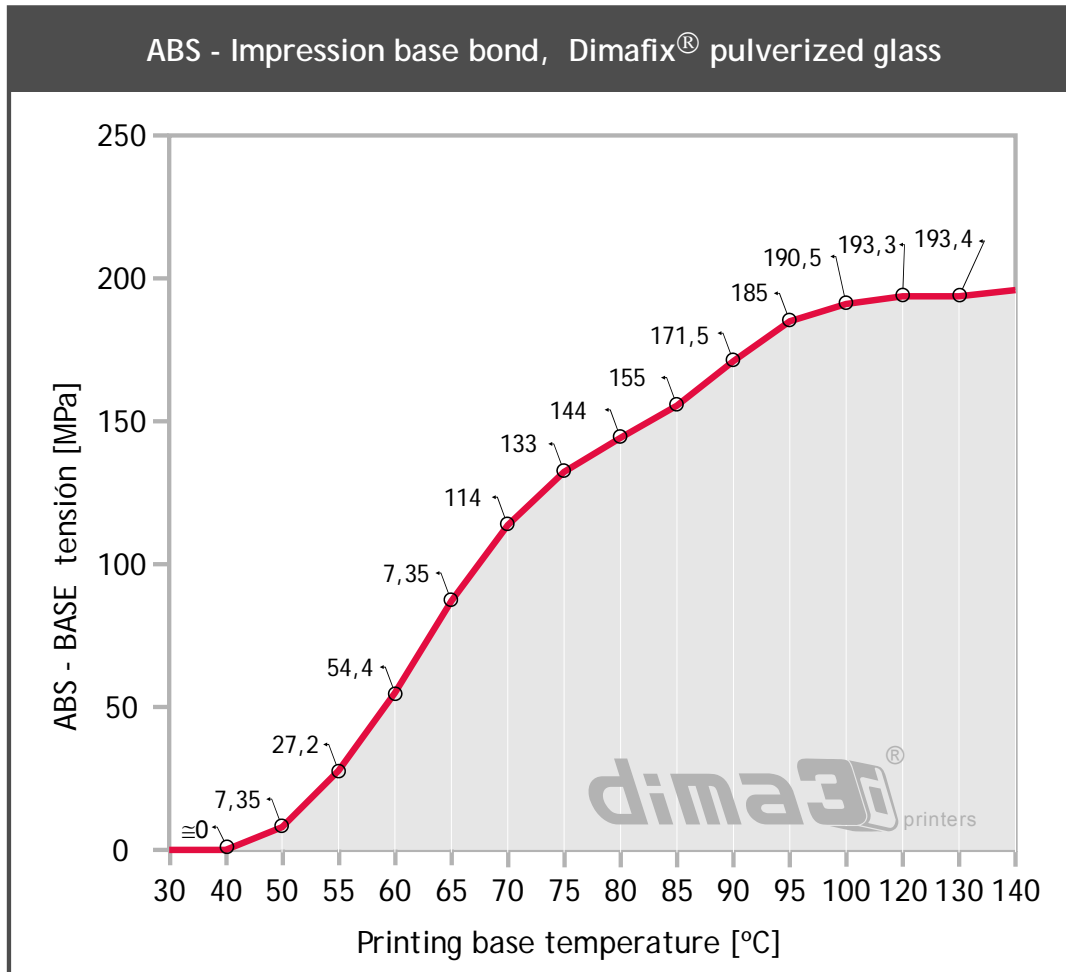

Figure 1. ABS – Printing bed tension variation depending on the temperature

Dimafix® provides maximum ABS adherence to printing surfaces made of regular, heat-treated or borosilicate glasses. For each printing and type of piece there is an optimal temperature for which Dimafix® completely avoids warping, as it is represented in Figure 2.

Dimafix® behaviour with ABS

Dimafix® provides different adherence values between the printed parts and the bed as the temperature varies. This is an essential feature for 3D printing and allows to distinguish four regions of operation where the user can obtain different useful behaviours by setting different



temperature values in the 3D printer's bed. These behaviours will allow to print ABS easily and successfully.

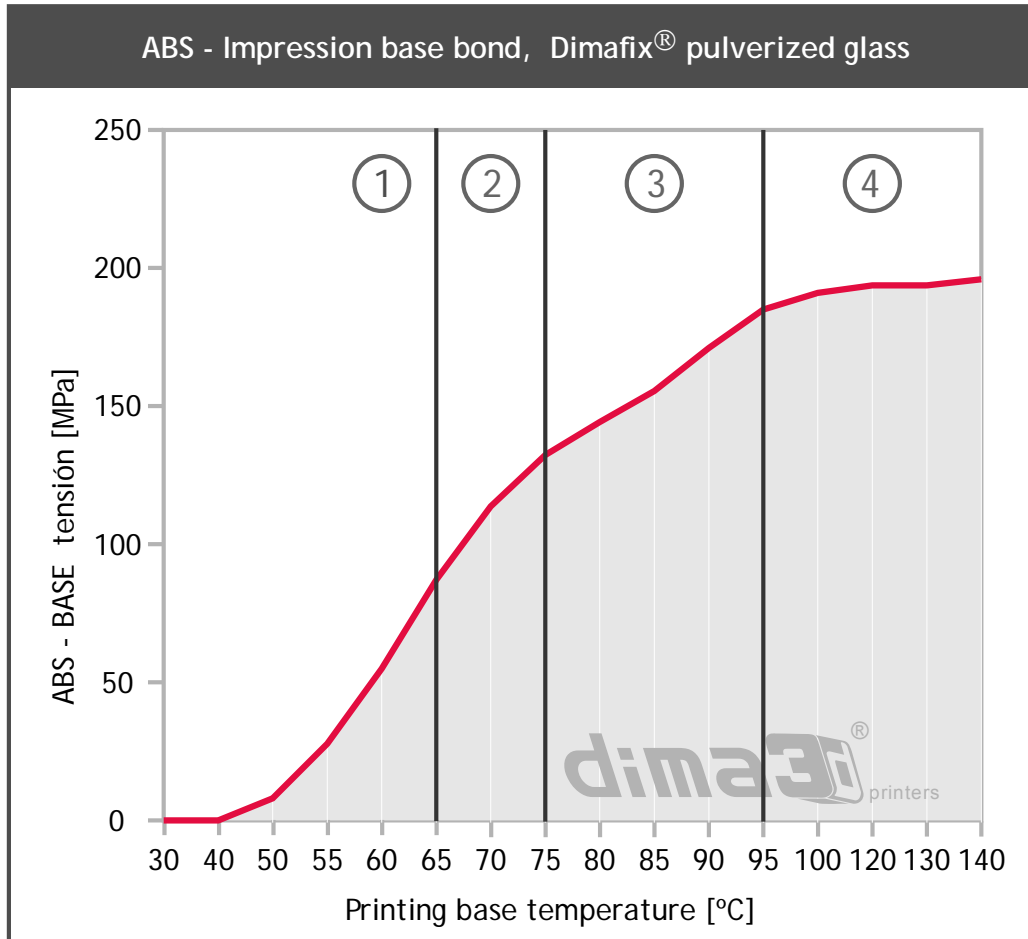

Figure 2. DimaFix[®] operation regions

These four operating temperature ranges vary the adherence power of Dimafix[®]. Some printing recommendations are given below depending on the type of piece to be printed (also summarised in Figure 3).

Zona 4. Bed temperature between 95°C and 120°C (203°F - 248°F)

Maximum adherence region. Any piece size and geometry can be printed without warping. The adherence tension between the piece and the bed is maximum, allowing any stress concentration factor. These are the optimum values to guarantee the best quality in sharp edges and vertices, which generally tend to concentrate internal tensions due to temperature.

These settings are also recommended to print large and complex pieces that require long printing times. The maximum area tested so far has been 480 mm × 240 mm (18.9 × 9,45 inches) continuously printing during more than 48 hours.



Zona 3. Bed temperature between 75°C and 95°C (167°F - 203°F)

High adherence region. Any type of geometry can be printed, especially for those pieces up to 200 × 200 mm (7,87 × 7,87 inches), the most common size for desktop 3D printers. It is recommended for good quality in sharp edges and vertices not affected by high cooling tensions (due to the stress concentration caused by temperature). It can also provide good results for long printing times.

Zona 2. Bed temperature between 65°C and 75°C (149°F - 167°F)

Medium adherence region. Recommended for simple pieces without sharp edges, vertices or complex geometries. Useful for rounded bases, chamfers, curves, etc., avoiding sharp edges or slim profiles which are long and thick at the same time. Also used for medium printing times.

Zona 1. Bed temperature below 65°C (149°F)

Self-detachment region. As long as the bed is cooled below this temperature, the printed parts detach from the bed automatically on their own, without any user action.

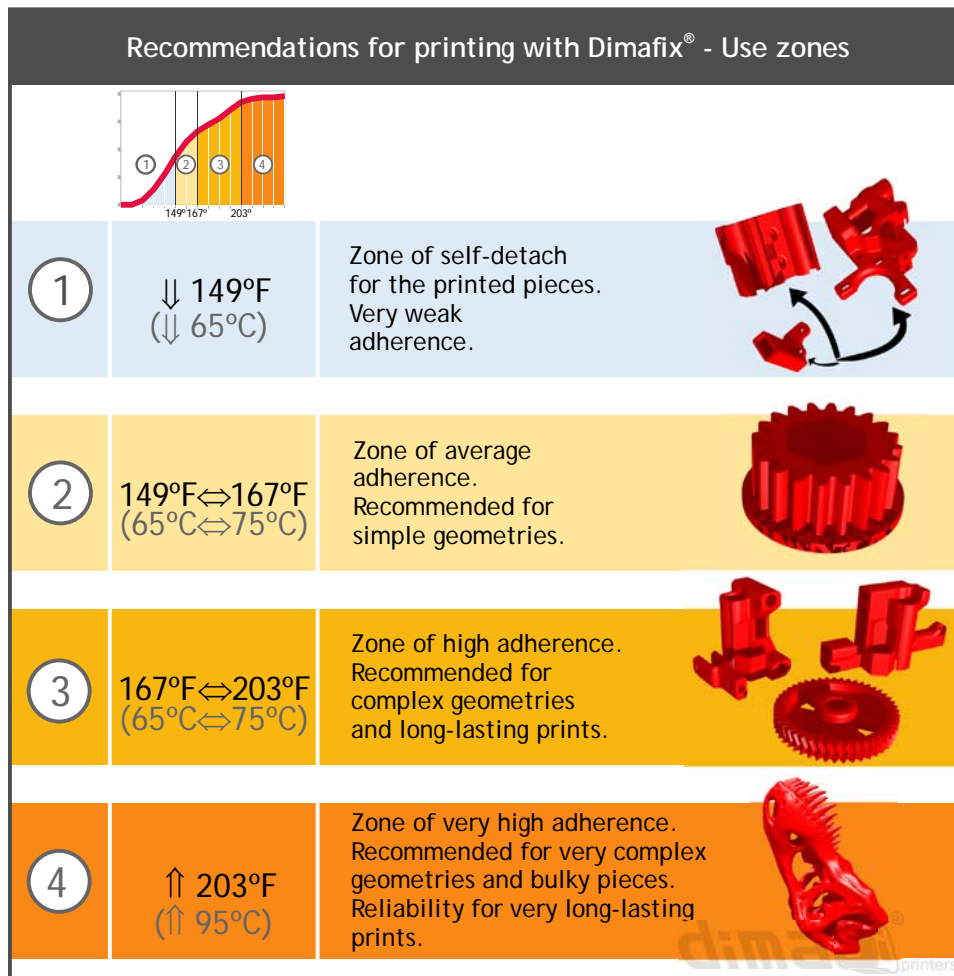

Figure 3. Dimafix® features for different operating temperature ranges



Tensions and strains analysis

Dimafix® creates an interface between the polymer (ABS) and the substratum (glass) that provides the required adherence to avoid internal tensions (created by the multidimensional thermal gradient) to detach the printings from the bed.

According to solid elasticity studies, every solid geometry free from physical constraints, isotropic, homogeneous and with a linear thermal gradient (it warms up homogeneously), is deformed without any internal tension. However, in our case:

- 1- The solid is bond to the adhesive Dimafix® interface to achieve a completely flat surface without any deformation. Therefore the solid is not free and has physical restrictions in the face next to the glass.
- 2- The thermal gradient is not linear. There are to heat sources, one due to the funded material deposition coming out from the extruder, and the other one due to the heating of the printing bed (which activates the properties of Dimafix®).
- 3- The solid is not isotropic because it is 3D printed. It is built with successive polymer layers deposition, therefore preventing the existence of isotropy.

A Finite Element Analysis (FEA) has been carried out taking into account all the previous concerns, assisted by the CAE software (Computer Aided Engineering) ANSYS V.14, using the modules “Steady-State Thermal” and “Static Structural”.

This study had the following conditions and considerations:

- 1- The geometry to be printed is represented in Figure 4. It will be printed as it is shown: supporting only over its minor and slim base. This geometry is commonly used in 3D printing to test adherence to the printing bed.

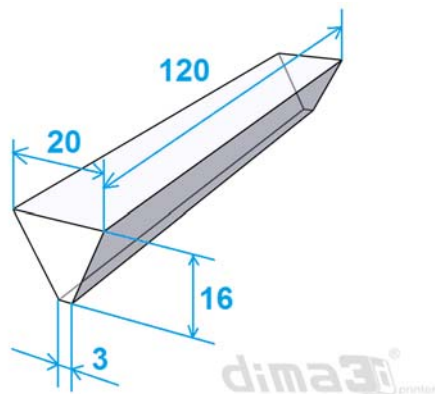

Figure 4. Geometry of the piece to be printed (size in mm)

- 2- Own database of printing material properties. Figure 5 shows the ABS data from MATWEB for the temperature values of the different geometry positions.



Overview of materials for Acrylonitrile Butadiene Styrene (ABS), Extruded			
Physical Properties	Metric	English	Comments
Density	0.350 - 3.50 g/cc	0.0126 - 0.126 lb/in ³	Average value: 1.06 g/cc Grade Count:377
Water Absorption	0.0250 - 2.30 %	0.0250 - 2.30 %	Average value: 0.407 % Grade Count:78
Moisture Absorption at Equilibrium	0.150 - 0.220 %	0.150 - 0.220 %	Average value: 0.200 % Grade Count:23
Water Absorption at Saturation	0.300 - 1.03 %	0.300 - 1.03 %	Average value: 0.734 % Grade Count:20
Viscosity	255000 - 255000 cP @Temperature 240 - 240 °C	255000 - 255000 cP @Temperature 464 - 464 °F	Average value: 255000 cP Grade Count:1
Mechanical Properties	Metric	English	Comments
Hardness, Rockwell R	90.0 - 119	90.0 - 119	Average value: 107 Grade Count:209
Hardness, H358/30	85.0 - 104 MPa	12300 - 15100 psi	Average value: 93.1 MPa Grade Count:9
Ball Indentation Hardness	80.0 - 120 MPa	11600 - 17400 psi	Average value: 98.6 MPa Grade Count:24
Tensile Strength, Ultimate	24.1 - 73.1 MPa 20.0 - 52.0 MPa @Temperature -18.0 - 90.0 °C	3500 - 10600 psi 2900 - 7540 psi @Temperature -0.400 - 194 °F	Average value: 38.5 MPa Grade Count:148 Average value: 35.8 MPa Grade Count:3
Tensile Strength, Yield	20.0 - 73.1 MPa 64.0 - 64.0 MPa @Temperature -18.0 °C	2900 - 10600 psi 9280 - 9280 psi @Temperature -0.400 °F	Average value: 43.2 MPa Grade Count:329 Average value: 64.0 MPa Grade Count:1
Elongation at Break	1.40 - 110 % 15.0 - 15.0 % @Temperature -18.0 °C	1.40 - 110 % 15.0 - 15.0 % @Temperature -0.400 °F	Average value: 25.2 % Grade Count:247 Average value: 15.0 % Grade Count:1
Elongation at Yield	1.70 - 20.0 %	1.70 - 20.0 %	Average value: 3.41 % Grade Count:129
Modulus of Elasticity	0.778 - 6.10 GPa 2.81 - 2.81 GPa @Temperature -18.0 °C	113 - 885 ksi 408 - 408 ksi @Temperature -0.400 °F	Average value: 2.30 GPa Grade Count:220 Average value: 2.81 GPa Grade Count:1

Figure 5. Engineering data from MATWEB

3- Temperature boundary conditions:

- a. Extruder temperature: 240°C (464°F). Uniformly applied in the upper face of the piece, as a simplification of the real thermal distribution generated by the nozzle.
- b. Homogeneous natural convection in the four sides:
 - i. Approximated temperature: 18,6°C (65,48°F).
 - ii. Fluid: air.
 - iii. Air speed: 0,01m/s (0,022 miles per hour).
 - iv. Relative humidity: 91%.
- c. Bed temperature variable depending on the trial.

4- Application of uniformly sprayed Dimafix® over the area of the glass where the piece will be printed.

5- Glass printing surface, borosilicate derivatives without surface treatment.

Five different temperature values for the printing bed will be studied, determining the temperature gradients that generate, next to the base constraint, the appearance of internal tensions to be studied later on.



Analysis of the multidimensional thermal gradient

The piece has zones at different temperatures while it is printed. These temperature variations in the solid, next to the boundary conditions already described, generate internal tensions and hence deformations.

The multidimensional thermal gradient has to be known to study the deformations, this is, the spatial thermal function per volume differential of the geometry. The different regions of the solid will be limited by isothermal curves. The portion of solid for each volume differential will be at the same temperature.

In the lower face of the solid the bed temperature is applied, which produces a heat flow upwards (+Y axis). The fused polymer at 240°C (464°F) is applied in the upper face, producing a heat flow downwards. Both flows are produced by conduction. At the same time, thermal dissipation of heat is produced by convection between the solid's walls and the surrounding environment.

When the bed is at 70°C (158°F) the isothermal volume of the solid in the base starts at 58,9°C (138°F), due to the low thermal conductivity of ABS and a less responsive finite element mesh, as it is represented in Figure 6.

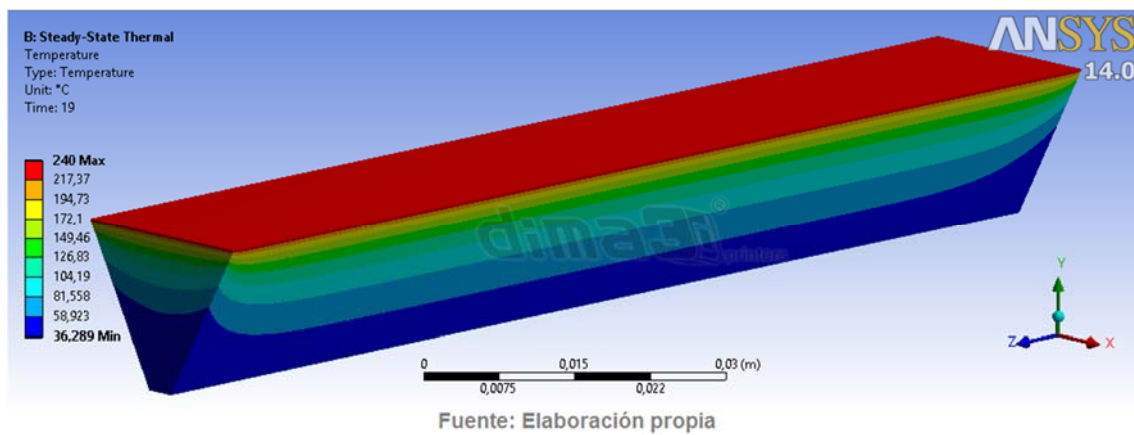

Figure 6. Thermal gradient with bed at 70°C (158°F)

However, an isothermal volume appears in the lower face of the piece by establishing the bed temperature at 80 °C (176°F), as it is shown in Figure 7 in light blue. It can be observed that the temperature gradient is not linear.

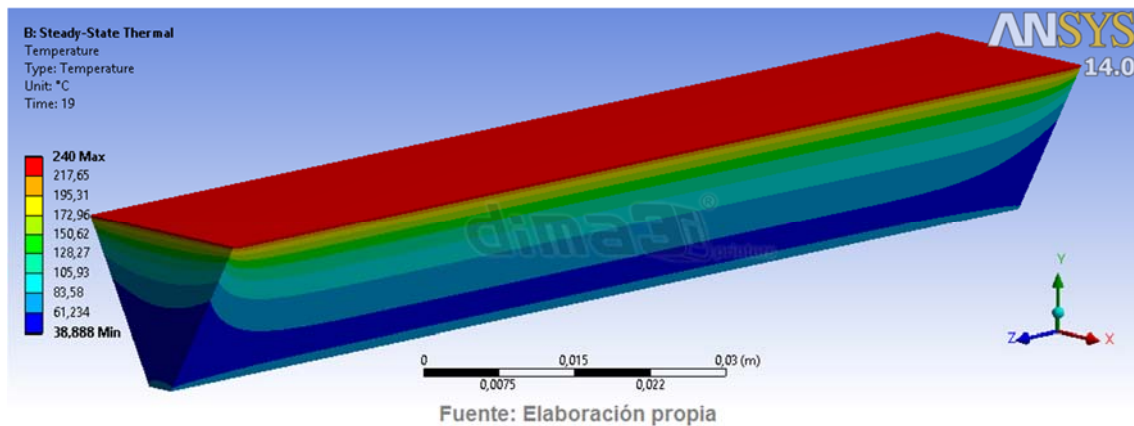

Figure 7. Thermal gradient with bed at 80°C (176°F)

In a similar way, by raising the temperature up to 90°C (194°F) as it is shown in Figure 8, the same isothermal volume grows respect to the previous case.

At the same time another positive consequence appears: with a higher temperature in the lower face, the value of the derivative of the multidimensional temperature gradient becomes lower, therefore showing that the temperature homogeneity increases inside the solid.

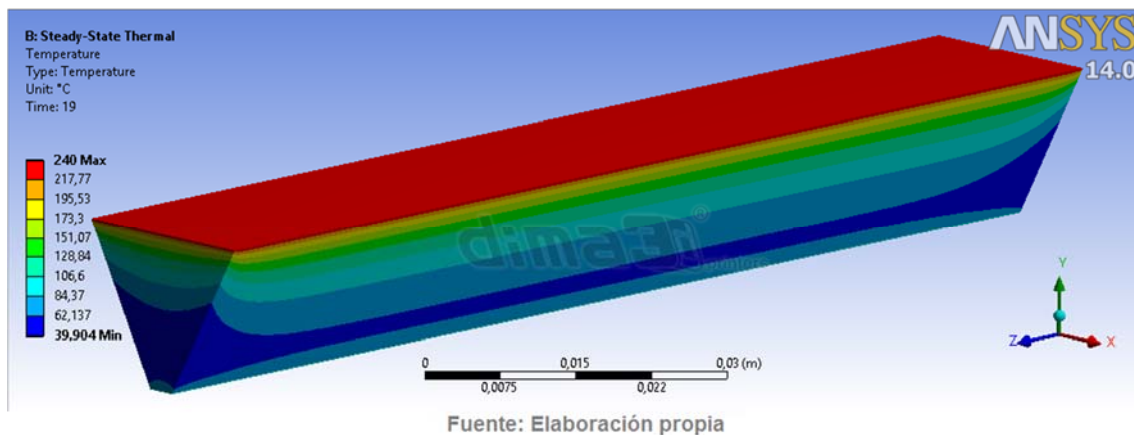

Figure 8. Thermal gradient with bed at 90°C (194°F)

Eventually, when the bed temperature is 110°C (230°F), following the previous argumentation, the homogeneity of temperature values increases more as two isothermal volumes join. Figure 9 shows this effect, where two isothermal volumes at lower temperature in the ends of the solid can be distinguished. Their multidimensional temperature gradient derivative will be maximum (although the tension between the solid and the substratum is also maximum). Next to the already described boundary conditions, this explains the appearance of internal tensions that create deformations in the ends, mainly caused by the deposition of funded material in the upper face.

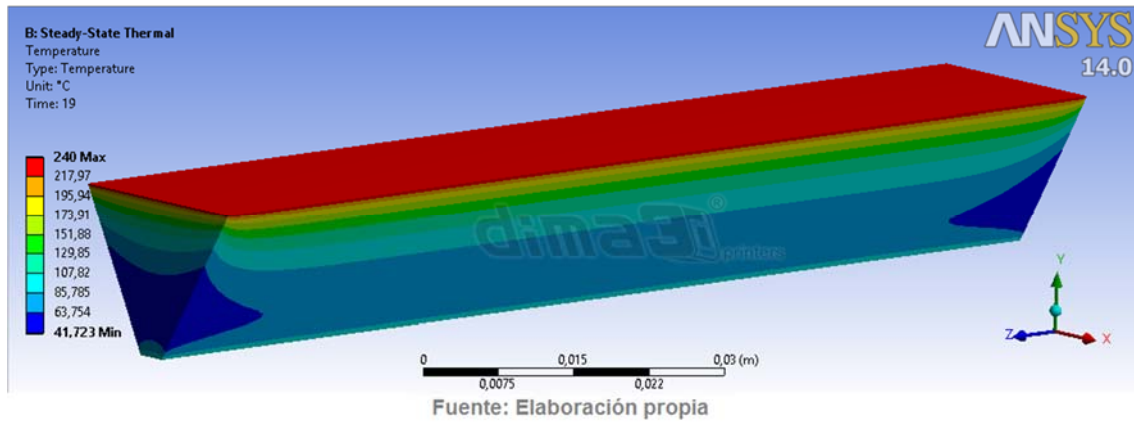

Figure 9. Thermal gradient with bed at 110°C (230°F)

During the printing, as it can be observed in Figures 6 to 9, the zone with lower temperature (50°C, 122°F) is reduced as the bed temperature is increased, making it more homogeneous along the solid. Therefore, we can conclude that the solid's thermal homogeneity increases with the bed temperature. Increasing the temperature homogeneity, the internal tensions created by large gradients in small differentials of the solid are reduced.

The final conclusion is that raising the bed temperature:

- the adherence properties of Dimafix® are activated,
- the solid's internal tensions are reduced, jointly with the bed interface provided by Dimafix®.



Analysis of deformations printing with ABS: warping

In this section we will study the deformation (“warping”) produced printing with ABS:

- first, without using Dimafix®;
- then, how the use of Dimafix® is capable of preventing warping completely.

The results will be analysed in terms of the highest deformation value measured. We will be able to conclude how the deformation value in the corners of the solid is significantly reduced when using Dimafix® instead of other common lacs.

This way, Figure 10 shows that a regular lac provides a deformation value of 2,089mm in the Y axis. In the Figures 11 to 14 it can be observed how this deformation value is significantly reduced as the bed temperature increases and Dimafix® is used. This is consistent with the adherence values represented in Figure 1 and their improvement with the bed temperature.

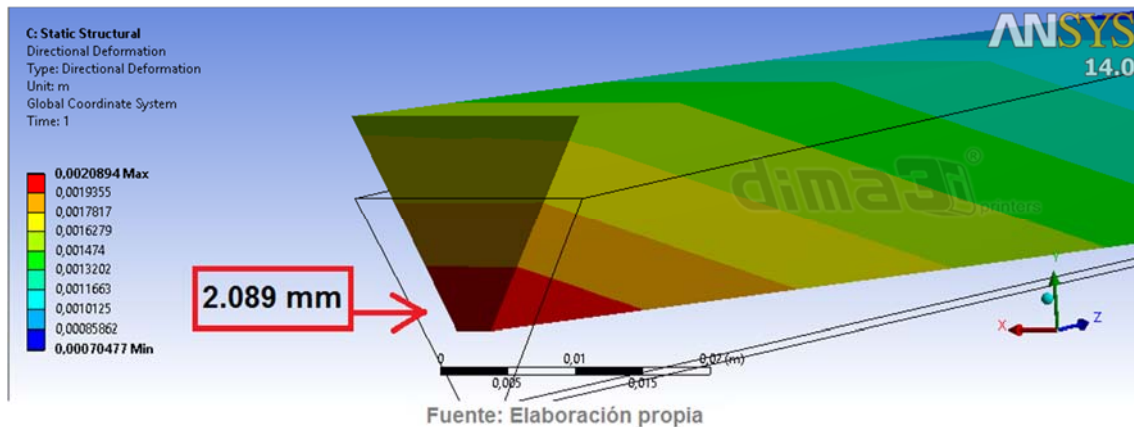

Figure 10. Deformation caused by internal tensions printing with regular lacs at 75°C (167°F)

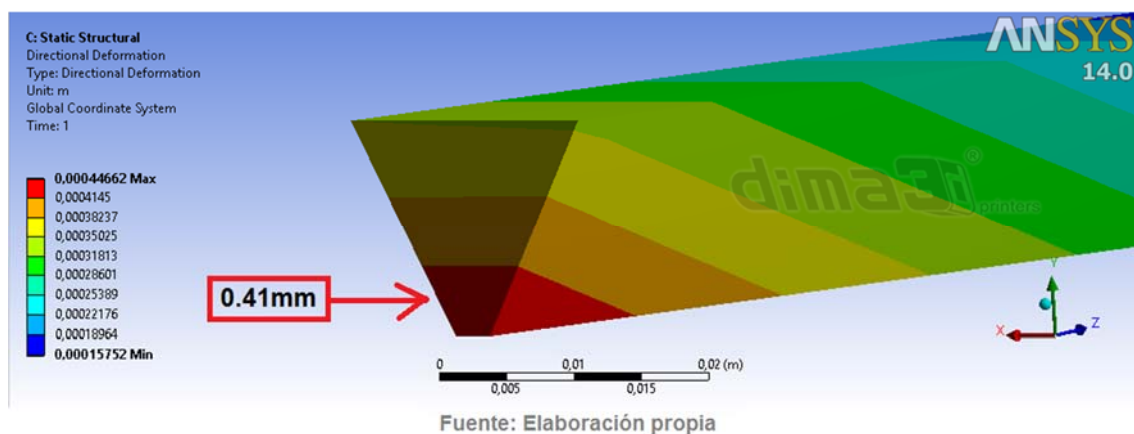

Figure 11. Deformation caused by internal tensions printing with Dimafix® at 75°C (167°F)

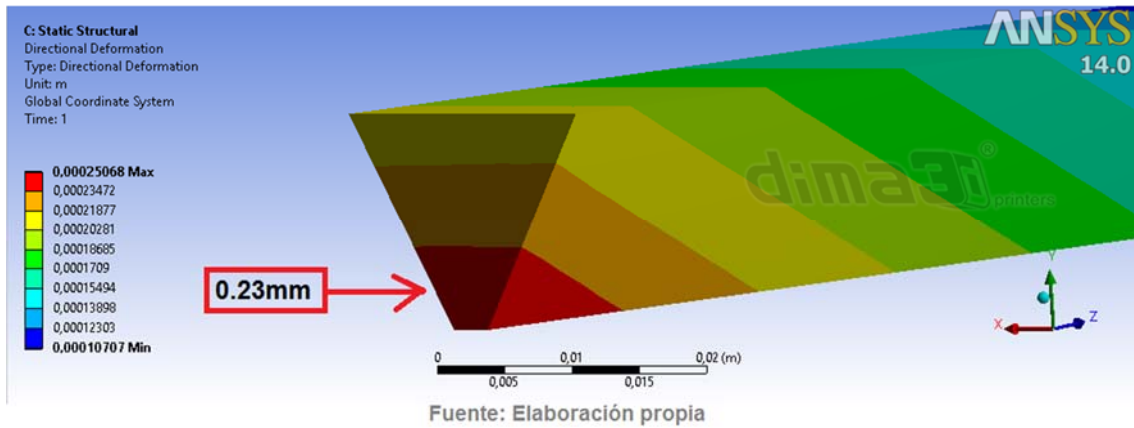

Figure 12. Deformation caused by internal tensions printing with Dimafix® at 80°C (176°F)

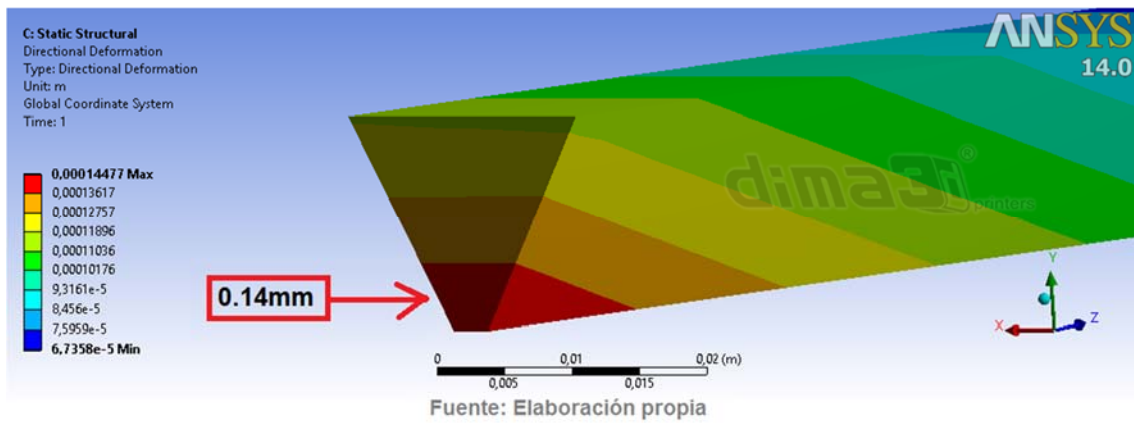

Figure 13. Deformation caused by internal tensions printing with Dimafix® at 90°C (194°F)

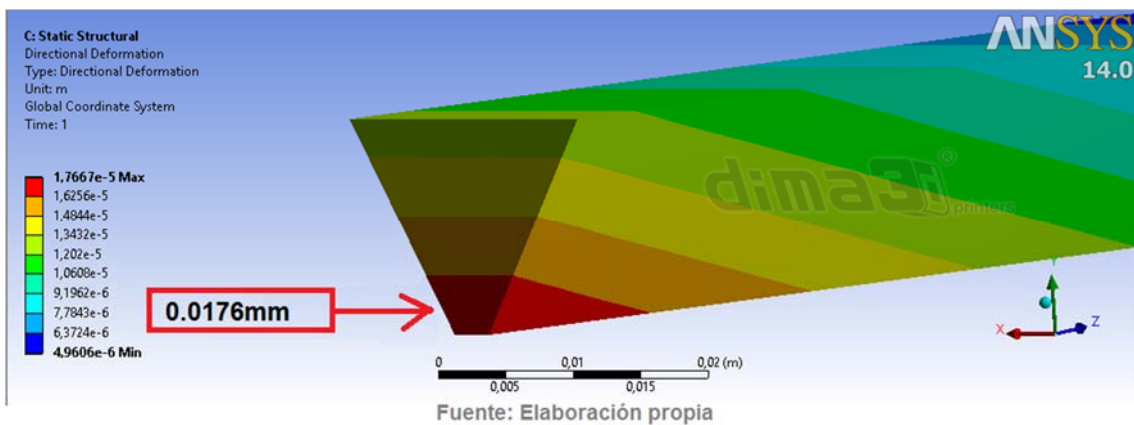

Figure 14. Deformation caused by internal tensions printing with Dimafix® at 110°C (230°F)

The deformations shown in the previous finite element analysis follow the Y axis in the relative coordinated system used. The colour scale values indicate deformation in meters in the lower end of the solid under study.



In the final step, this deformation in the end of the solid, where the tensions are maximum, will be studied. Figure 15 shows the local axis system used for this study.

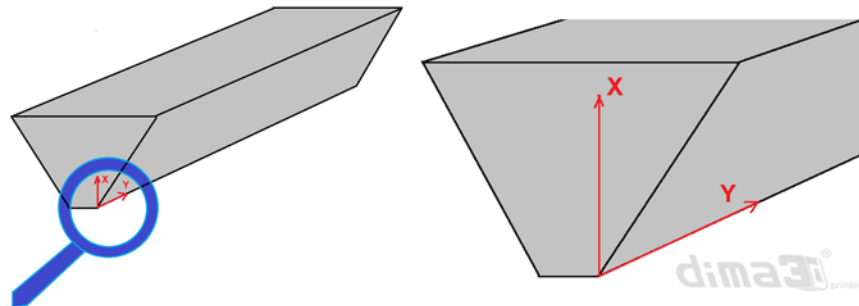

Figure 15. Axis system for the end deformation study

Figure 16 represents the results obtained from our study, comparing Dimafix® versus regular lacs, for bed temperatures from 75°C up to 110°C (167°–230°F). The results confirm that the deformations in the end of the solid are much smaller using Dimafix®.

This way, for 75°C (167°F), the deformation with the regular lac is already five times larger than the deformation with Dimafix® at the same temperature. As the bed temperature is increased, the adherence of Dimafix® becomes even stronger and the deformations become one hundred times smaller.

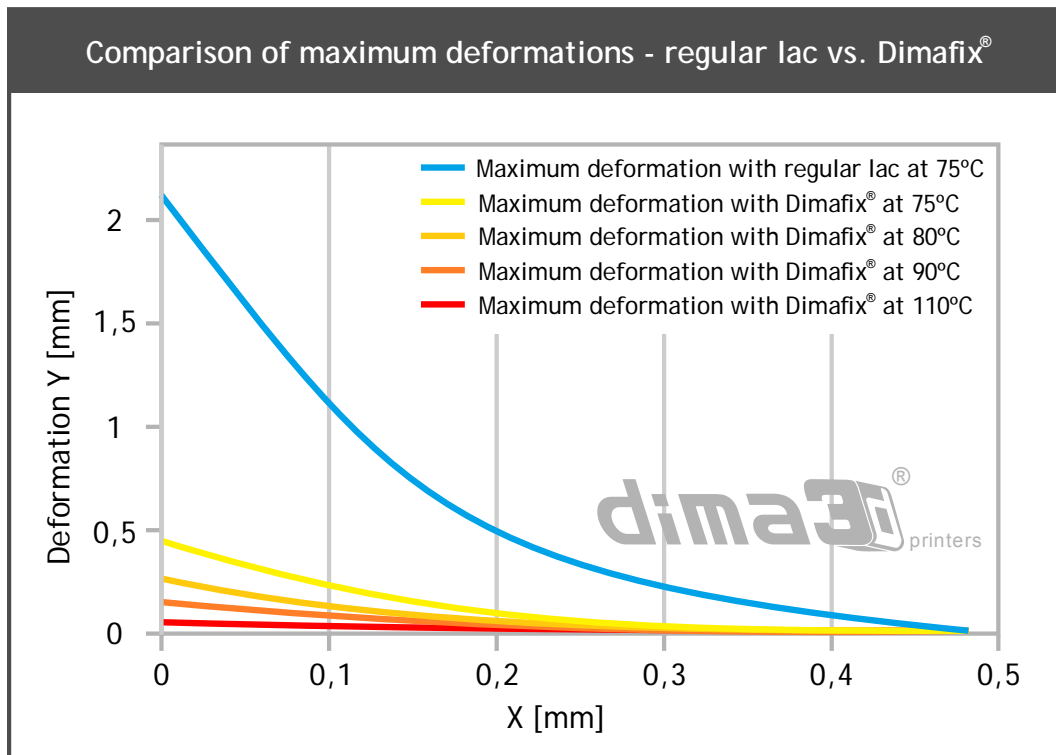

Figure 16. Deformations at different temperatures – Dimafix® vs regular lacs



DIMAFIX PEN
Code: EX014S0999



Version: 1 Date of compilation: 13/09/2016

Date of printing: 13/09/2016

SECTION 1 : IDENTIFICATION OF THE SUBSTANCE/MIXTURE AND OF THE COMPANY/UNDERTAKING

1.1	PRODUCT IDENTIFIER: DIMAFIX PEN Code: EX014S0999
1.2	RELEVANT IDENTIFIED USES AND USES ADVISED AGAINST: <u>Intended uses (main technical functions):</u> [X] Industrial [X] Professional [X] Consumers Fixing 3D printing dabber <u>Sectors of use:</u> Consumer uses (SU21). <u>Uses advised against:</u> This product is not recommended for any use or sector of use industrial, professional or consume other than those previously listed as 'Intended or identified uses'. <u>Restrictions on manufacture, placing on market and use, according to Annex XVII of Regulation (EC) No. 1907/2006:</u> Not restricted.
1.3	DETAILS OF THE SUPPLIER OF THE SAFETY DATA SHEET: DIMA 3D, S.L. C/ Arenal, 12 - Nave 4, 47155 Santovenia de Pisuegra, Valladolid (Spain) Phone: +34 983 130 005 E-mail address of the person responsible for the safety data sheet: e-mail: soporte@dima3d.com
1.4	EMERGENCY TELEPHONE NUMBER: (+34) 983 130 005 (9:00-17:00 h.) (working hours)

SECTION 2 : HAZARDS IDENTIFICATION

2.1	CLASSIFICATION OF THE SUBSTANCE OR MIXTURE: <u>Classification in accordance with Regulation (EC) No. 1272/2008-605/2014 (CLP):</u> DANGER: Flam. Liq. 2:H225 Eye Irrit. 2:H319 STOT SE (narcosis) 3:H336					
	Danger class	Classification of the mixture	Cat.	Routes of exposure	Target organs	Effects
	<u>Physicochemical:</u> 	Flam. Liq. 2:H225 Eye Irrit. 2:H319 STOT SE (narcosis) 3:H336	Cat.2 Cat.2 Cat.3	- Eyes Inhalation	- Eyes CNS	- Irritation Narcosis
	<u>Human health:</u> 					
	<u>Environment:</u> Not classified					
Full text of hazard statements mentioned is indicated in section 16.						
Note: When in section 3 a range of percentages is used, the health and environmental hazards describe the effects of the highest concentration of each component, but below the maximum value.						

2.2	LABEL ELEMENTS: This product is labelled with the signal word DANGER in accordance with Regulation (EC) No. 1272/2008-605/2014 (CLP)					
	<u>Hazard statements:</u> H225 H319 H336	Highly flammable liquid and vapour. Causes serious eye irritation. May cause drowsiness or dizziness.				
	<u>Precautionary statements:</u> P101 P102 P103 P210 P280F P303+P361+P353 P304+P340-P312 P305+P351+P338-P310 P337+P313 P501a	If medical advice is needed, have product container or label at hand. Keep out of reach of children. Read label before use. Keep away from heat, hot surfaces, sparks, open flames and other ignition sources. No smoking. Wear protective gloves, clothing and eye protection. In case of inadequate ventilation wear respiratory protection. IF ON SKIN (or hair): Take off immediately all contaminated clothing. Rinse skin with water/shower. IF INHALED: Remove person to fresh air and keep comfortable for breathing. Call a POISON CENTER or doctor if you feel unwell. IF IN EYES: Rinse cautiously with water for several minutes. Remove contact lenses, if present and easy to do. Continue rinsing. Immediately call a POISON CENTER or doctor. If eye irritation persists: Get medical attention. Dispose of contents/container in accordance with local regulations.				
	<u>Supplementary statements:</u> None.					
	<u>Hazardous ingredients:</u> Isopropyl alcohol					



DIMAFIX PEN
Code: EX014S0999



2.3 OTHER HAZARDS:
Hazards which do not result in classification but which may contribute to the overall hazards of the mixture:
Other physicochemical hazards: Vapours may form with air a mixture potentially flammable or explosive.
Other adverse human health effects: In case of prolonged contact, the skin may become dry.
Other negative environmental effects: # Does not contain substances that fulfill the PBT/vPvB criteria.

SECTION 3 : COMPOSITION/INFORMATION ON INGREDIENTS

3.1 SUBSTANCES:
Not applicable (mixture).

3.2 MIXTURES:
This product is a mixture.
Chemical description:
Solution of resin.
HAZARDOUS INGREDIENTS:
Substances taking part in a percentage higher than the exemption limit:

70 < 80 %		Ethyl alcohol CAS: 64-17-5 , EC: 200-578-6 CLP: Danger: Flam. Liq. 2:H225 Eye Irrit. 2:H319	REACH: 01-2119457610-43	Index No. 603-002-00-5 < REACH
10 < 15 %		Isopropyl alcohol CAS: 67-63-0 , EC: 200-661-7 CLP: Danger: Flam. Liq. 2:H225 Eye Irrit. 2:H319 STOT SE (narco) 3:H336	REACH: 01-2119457558-25	Index No. 603-117-00-0 < REACH / ATP01
10 < 15 %		1-vinyl-2-pyrrolidone-vinyl acetate polymer CAS: 25086-89-9 , EC: Polymer CLP: Aquatic Chronic 4:H413		Autoclassified
1 < 2,5 %		n-butyl acetate CAS: 123-86-4 , EC: 204-658-1 CLP: Warning: Flam. Liq. 3:H226 STOT SE (narco) 3:H336 EUH066	REACH: 01-2119485493-29	Index No. 607-025-00-1 < REACH / ATP01

Impurities:
Does not contain other components or impurities which will influence the classification of the product.

Stabilizers:
None

Reference to other sections:
For more information on hazardous ingredients, see sections 8, 11, 12 and 16.

SUBSTANCES OF VERY HIGH CONCERN (SVHC):
List updated by ECHA on 20/06/2016.
Substances SVHC subject to authorisation, included in Annex XIV of Regulation (EC) no. 1907/2006:
None
Substances SVHC candidate to be included in Annex XIV of Regulation (EC) no. 1907/2006:
None

PERSISTENT, BIOACCUMULABLE AND TOXIC PBT, OR VERY PERSISTENT AND VERY BIOACCUMULABLE VPvB SUBSTANCES:
Does not contain substances that fulfill the PBT/vPvB criteria.





DIMAFIX PEN
Code: EX014S0999



SECTION 4 : FIRST AID MEASURES

4.1 DESCRIPTION OF FIRST-AID MEASURES AND MAIN SYMPTOMS AND EFFECTS, ACUTE AND DELAYED:

4.2  Symptoms may occur after exposure, so that in case of direct exposure to the product, when in doubt, or when symptoms persist, seek medical attention. Never give anything by mouth to an unconscious person. Lifeguards should pay attention to self-protection and use the recommended protective equipment if there is a possibility of exposure. Wear protective gloves when administering first aid.

Route of exposure	Symptoms and effects, acute and delayed	Description of first-aid measures
<u>Inhalation:</u> 	Inhalation of solvent vapours may produce headache, dizziness, fatigue, muscular weakness, drowsiness and, in extreme cases, unconsciousness.	Remove the patient out of the contaminated area into the fresh air. If breathing is irregular or stops, administer artificial respiration. If the person is unconscious, place in appropriate recovery position. Keep the patient warm and at rest until medical attention arrives.
<u>Skin:</u>	In case of prolonged contact, the skin may become dry.	Remove immediately contaminated clothing. Wash thoroughly the affected area with plenty of cold or lukewarm water and neutral soap, or use a suitable skin cleanser. Do not use solvents or thinners.
<u>Eyes:</u> 	Contact with the eyes produces redness and pain.	Remove contact lenses. Rinse eyes copiously by irrigation with plenty of clean, fresh water for at least 15 minutes, holding the eyelids apart, until the irritation is reduced. Call a physician immediately.
<u>Ingestion:</u>	If swallowed, may cause irritation of the throat, abdominal pain, drowsiness, nausea, vomiting and diarrhoea.	If swallowed, seek medical advice immediately and show container or label. Do not induce vomiting, due to the risk of aspiration. Keep the patient at rest.

4.3 **INDICATION OF ANY IMMEDIATE MEDICAL ATTENTION AND SPECIAL TREATMENT NEEDED:**
Notes to physician: Treatment should be directed at the control of symptoms and the clinical condition of the patient.
Antidotes and contraindications: Specific antidote not known.

SECTION 5 : FIRE-FIGHTING MEASURES

- 5.1 **EXTINGUISHING MEDIA:**
Extinguishing powder or CO2. In the case of more important fires, also alcohol resistant foam and water spray/mist. Do not use for extinguishing: direct water jet. Direct water jet may not be effective to extinguish the fire, since the fire may spread.
- 5.2 **SPECIAL HAZARDS ARISING FROM THE SUBSTANCE OR MIXTURE:**
Highly flammable liquid and vapour. As consequence of combustion or thermal decomposition, hazardous products may be produced: carbon monoxide, carbon dioxide, nitrogen oxides. Irritant. Exposure to combustion or decomposition products may be a hazard to health.
- 5.3 **ADVICE FOR FIREFIGHTERS:**
Special protective equipment: Depending on magnitude of fire, heat-proof protective clothing may be required, appropriate independent breathing apparatus, gloves, protective glasses or face masks and boots. If the fire-proof protective equipment is not available or not used, combat fire from a sheltered position or at a safe distance. The standard EN469 provides a basic level of protection for chemical incidents.
Other recommendations: Cool with water the tanks, cisterns or containers close to sources of heat or fire. Bear in mind the direction of the wind. Do not allow fire-fighting residue to enter drains, sewers or water courses.

SECTION 6 : ACCIDENTAL RELEASE MEASURES

- 6.1 **PERSONAL PRECAUTIONS, PROTECTIVE EQUIPMENT AND EMERGENCY PROCEDURES:**
Eliminate possible sources of ignition and when appropriate, ventilate the area. Do not smoke. Avoid direct contact with this product. Avoid breathing vapours. Keep people without protection in opposition to the wind direction.
- 6.2 **ENVIRONMENTAL PRECAUTIONS:**
Avoid contamination of drains, surface or subterranean water and soil. In the case of large scale spills or when the product contaminates lakes, rivers or sewages, inform the appropriate authorities in accordance with local regulations.
- 6.3 **METHODS AND MATERIAL FOR CONTAINMENT AND CLEANING UP:**
Contain and mop up spills with non-combustible absorbent materials (earth, sand, vermiculite, diatomaceous earth, etc..). Clean preferably with a biodegradable detergent. Keep the remains in a closed container.
- 6.4 **REFERENCE TO OTHER SECTIONS:**
For contact information in case of emergency, see section 1.
For information on safe handling, see section 7.
For exposure controls and personal protection measures, see section 8.
For subsequent waste disposal, follow the recommendations in section 13.



DIMAFIX PEN
Code: EX014S0999



SECTION 7 : HANDLING AND STORAGE

7.1 PRECAUTIONS FOR SAFE HANDLING:
 Comply with the existing legislation on health and safety at work.
General recommendations:
 Avoid any type of leakage or escape. Keep the container tightly closed.
Recommendations for the prevention of fire and explosion risks:
 Vapours are heavier than air, may spread along floors to a considerable distance, can form explosive mixtures with air and are able to reach distant ignition sources and flame up or explode. Due to its flammability, this material should only be used in areas from which all naked lights and other sources of ignition have been excluded and away from other heat or electrical sources. Switch mobile phones off and do not smoke. No tools with a potential for sparks should be used.

- Flash point	:	14. °C
- Autoignition temperature	:	426. °C
- Upper/lower flammability or explosive limits	:	3.1 - 18.1 % Volume 25°C

Recommendations for the prevention of toxicological risks:
 Do not eat, drink or smoke while handling. After handling, wash hands with soap and water. For exposure controls and personal protection measures, see section 8.
Recommendations for the prevention of environmental contamination:
 It is not considered a danger to the environment. In the case of accidental spillage, follow the instructions indicated in section 6.

7.2 CONDITIONS FOR SAFE STORAGE, INCLUDING ANY INCOMPATIBILITIES:
 Forbid the entry to unauthorized persons. Keep out of reach of children. This product should be stored isolated from heat and electrical sources. Do not smoke in storage area. If possible, avoid direct contact with sunlight. Avoid extreme humidity conditions. In order to avoid leakages, the containers, after use, should be closed carefully and placed in a vertical position. For more information, see section 10.

<u>Class of store</u>	:	According to current legislation.
<u>Maximum storage period</u>	:	24. months
<u>Temperature interval</u>	:	min: 5.°C, max: 40.°C (recommended).

Incompatible materials:
 Keep away from oxidizing agents, from strongly alkaline and strongly acid materials.
Type of packaging:
 According to current legislation.
Limit quantity (Seveso III): Directive 2012/18/EU:
 Umbral inferior: 5000 toneladas , Umbral superior: 50000 toneladas

7.3 SPECIFIC END USES:
 For the use of this product do not exist particular recommendations apart from that already indicated.



DIMAFIX PEN
Code: EX014S0999



SECTION 8 : EXPOSURE CONTROLS/PERSONAL PROTECTION

8.1 CONTROL PARAMETERS:
If a product contains ingredients with exposure limits, may be necessary a personnel monitoring, work place or biological, to determine the effectiveness of the ventilation or other control measures and/or the necessity to use respiratory protective equipment. Reference should be made to EN689, EN14042 and EN482 standard concerning methods for assessing the exposure by inhalation to chemical agents, and exposure to chemical and biological agents. Reference should be also made to national guidance documents for methods for the determination of dangerous substances.

OCCUPATIONAL EXPOSURE LIMIT VALUES (TLV)

AGCIH 2014	Year	TLV-TWA		TLV-STEL		Remarks
		ppm	mg/m3	ppm	mg/m3	
Ethyl alcohol	1996	1000.	1880.	-	-	A4
Isopropyl alcohol	2003	200.	491.	400.	982.	A4
n-butyl acetate	1998	150.	713.	200.	950.	

TLV - Threshold Limit Value, TWA - Time Weighted Average, STEL - Short Term Exposure Limit.
A4 - Non classified as carcinogenic in humans.

BIOLOGICAL LIMIT VALUES:

Not established

DERIVED NO-EFFECT LEVEL (DNEL):

Derived no-effect level (DNEL) is a level of exposure that is considered safe, derived from toxicity data according to specific guidances included in REACH. DNEL values may differ from a occupational exposure limit (OEL) for the same chemical. OEL values may come recommended by a particular company, a government regulatory agency or an organization of experts. Although considered protective of health, the OEL values are derived by a process different of REACH.

<u>Derived no-effect level, workers:</u> - Systemic effects, acute and chronic:	<u>DNEL Inhalation</u> mg/m3		<u>DNEL Cutaneous</u> mg/kg bw/d		<u>DNEL Oral</u> mg/kg bw/d	
	Ethyl alcohol	s/r (a)	950. (c)	s/r (a)	343. (c)	- (a)
Isopropyl alcohol	- (a)	500. (c)	- (a)	888. (c)	- (a)	- (c)
n-butyl acetate	960. (a)	480. (c)	11.0 (a)	11.0 (c)	- (a)	- (c)
<u>Derived no-effect level, workers:</u> - Local effects, acute and chronic:	<u>DNEL Inhalation</u> mg/m3		<u>DNEL Cutaneous</u> mg/cm2		<u>DNEL Eyes</u> mg/cm2	
	Ethyl alcohol	1900. (a)	s/r (c)	s/r (a)	s/r (c)	- (a)
Isopropyl alcohol	- (a)	- (c)	- (a)	- (c)	- (a)	- (c)
n-butyl acetate	960. (a)	480. (c)	s/r (a)	s/r (c)	s/r (a)	- (c)
<u>Derived no-effect level, general population:</u> - Systemic effects, acute and chronic:	<u>DNEL Inhalation</u> mg/m3		<u>DNEL Cutaneous</u> mg/kg bw/d		<u>DNEL Oral</u> mg/kg bw/d	
	Ethyl alcohol	s/r (a)	114. (c)	s/r (a)	206. (c)	s/r (a)
Isopropyl alcohol	- (a)	89.0 (c)	- (a)	319. (c)	- (a)	26.0 (c)
n-butyl acetate	860. (a)	102. (c)	6.00 (a)	6.00 (c)	2.00 (a)	2.00 (c)
<u>Derived no-effect level, general population:</u> - Local effects, acute and chronic:	<u>DNEL Inhalation</u> mg/m3		<u>DNEL Cutaneous</u> mg/cm2		<u>DNEL Eyes</u> mg/cm2	
	Ethyl alcohol	950. (a)	s/r (c)	s/r (a)	s/r (c)	- (a)
Isopropyl alcohol	- (a)	- (c)	- (a)	- (c)	- (a)	- (c)
n-butyl acetate	860. (a)	102. (c)	s/r (a)	s/r (c)	s/r (a)	- (c)

(a) - Acute, short-term exposure, (c) - Chronic, long-term or repeated exposure.
(-) - DNEL not available (without data of registration REACH).
s/r - DNEL not derived (not identified hazard).

PREDICTED NO-EFFECT CONCENTRATION (PNEC):

<u>Predicted no-effect concentration, aquatic organisms:</u> - Fresh water, marine water and intermitent release:	<u>PNEC Fresh water</u> mg/l		<u>PNEC Marine</u> mg/l		<u>PNEC Intermittent</u> mg/l	
	Ethyl alcohol	0.960		0.790		2.75
Isopropyl alcohol	141.		141.		141.	
n-butyl acetate	0.180		0.0180		0.360	
<u>- Wastewater treatment plants (STP) and sediments in fresh- and marine water:</u>	<u>PNEC STP</u> mg/l		<u>PNEC Sediments</u> mg/kg dry weight		<u>PNEC Sediments</u> mg/kg dry weight	
	Ethyl alcohol	580.	3.60	2.90		
Isopropyl alcohol	2251.	552.	552.			
n-butyl acetate	35.6	0.981	0.981			0.0981
<u>Predicted no-effect concentration, terrestrial organisms:</u> - Air, soil and effects for predator sand humans:	<u>PNEC Air</u> mg/m3		<u>PNEC Soil</u> mg/kg dry weight		<u>PNEC Oral</u> mg/kg bw/d	
	Ethyl alcohol	-	0.630		720.	
Isopropyl alcohol	-	28.0		160.		
n-butyl acetate	s/r	0.0903		n/b		

(-) - PNEC not available (without data of registration REACH).
s/r - PNEC not derived (not identified hazard).
n/b - PNEC not derived (not bioaccumulative potential).



DIMAFIX PEN
Code: EX014S0999



8.2 EXPOSURE CONTROLS:

ENGINEERING MEASURES:



Provide adequate ventilation. Where reasonably practicable, this should be achieved by the use of local exhaust ventilation and good general extraction. If these measures are not sufficient to maintain concentrations of particulates and vapours below the Occupational Exposure Limits, suitable respiratory protection must be worn.

Protection of respiratory system: Avoid the inhalation of vapours.

Protection of eyes and face: It is recommended to dispose of water taps or sources with clean water close to the working area.

Protection of hands and skin: It is recommended to dispose of water taps or sources with clean water close to the working area. Barrier creams may help to protect the exposed areas of the skin. Barrier creams should not be applied once exposure has occurred.

OCUPATIONAL EXPOSURE CONTROLS: Directive 89/686/EEC-96/58/EC:

As a general measure on prevention and safety in the work place, we recommend the use of a basic personal protection equipment (PPE), with the corresponding EC marking. For more information on personal protective equipment (storage, use, cleaning, maintenance, type and characteristics of the PPE, protection class, marking, category, CEN norm, etc.), you should consult the informative brochures provided by the manufacturers of PPE.

Mask:



A-type filter mask (brown) for gases and vapours of organic compounds with a boiling point higher than 65°C (EN14387). Classe 1: low capacity up to 1000 ppm, Classe 2: medium capacity up to 5000 ppm, Classe 3: high capacity up to 10000 ppm. In order to obtain a suitable protection level, the filter class must be selected depending on the type and concentration of the contaminating agents present, in accordance with the specifications supplied by the filter producers. The respiratory equipment with filters does not work satisfactorily when the air contains high concentrations of vapour or oxygen content less than 18% in volume. In presence of high concentrations of vapour, use independent breathing apparatus.

Goggles:



Safety goggles designed to protect against liquid splashes, with suitable lateral protection (EN166). Clean daily and disinfect at regular intervals in accordance with the instructions of the manufacturer.

Face shield:

No.

Gloves:



Gloves resistant against chemicals (EN374). When it can be a repeated or prolonged contact, it is recommended to use gloves with a protection level 5 or higher, with a breakthrough time >240 min. When you only expects a short contact, it is recommended to use gloves with a protection level 2 or higher, with a breakthrough time >30 min. The breakthrough time of the selected glove material should be in accordance with the pretended period of use. There are several factors (for example, temperature), they do in practice the period of use of a protective gloves resistant against chemicals is clearly lower than the established standard EN374. Due to the wide variety of circumstances and possibilities, we must have in mind the manual of instructions from manufacturers of gloves. The gloves should be immediately replaced when any sign of degradation is noted.

Boots:

No.

Apron:

No.

Clothing:

No.

Thermal hazards:

Not applicable (the product is handled at room temperature).

ENVIRONMENTAL EXPOSURE CONTROLS:

Avoid any spillage in the environment. Avoid any release into the atmosphere.

Spills on the soil: Prevent contamination of soil.

Spills in water: Do not allow to escape into drains, sewers or water courses.

- **Water Control Act:** Este producto no contiene ninguna sustancia incluida en la lista de sustancias prioritarias en el ámbito de la política de aguas, según la Directiva 2000/60/CE-2013/39/UE.

Emissions to the atmosphere: Because of volatility, emissions to the atmosphere while handling and use may result. Avoid any release into the atmosphere.

- **VOC (industrial installations):** Si el producto se utiliza en una instalación industrial, se debe verificar si es de aplicación la Directiva 2010/75/UE (RD.117/2003-RD.815/2013), relativa a la limitación de emisiones de compuestos orgánicos volátiles debidas al uso de disolventes orgánicos en determinadas actividades industriales: Disolventes : 89.2% Peso , COV (suministro) : 89.2% Peso , COV : 47.9% C (expresado como carbono) , Peso molecular (medio) : 50.3 , Número átomos C (medio) : 2.3.



DIMAFIX PEN
Code: EX014S0999



SECTION 9 : PHYSICAL AND CHEMICAL PROPERTIES

9.1	<p>INFORMATION ON BASIC PHYSICAL AND CHEMICAL PROPERTIES:</p> <p><u>Appearance</u></p> <ul style="list-style-type: none"> - Physical state : Liquid. - Odour : Characteristic - Odour threshold : Not available (mixture). <p><u>pH-value</u></p> <ul style="list-style-type: none"> - pH : Not applicable <p><u>Change of state</u></p> <ul style="list-style-type: none"> - Melting point : Not applicable (mixture). - Initial boiling point : 78.3 °C at 760 mmHg <p><u>Density</u></p> <ul style="list-style-type: none"> - Relative density : 0.826 at 20/4°C Relative water <p><u>Stability</u></p> <ul style="list-style-type: none"> - Decomposition temperature : Not available <p><u>Viscosity:</u></p> <ul style="list-style-type: none"> - Viscosity (flow time) : Not available <p><u>Volatility:</u></p> <ul style="list-style-type: none"> - Vapour pressure : 5.8 kPa at 20°C - Vapour pressure : 29. kPa at 50°C <p><u>Solubility(ies)</u></p> <ul style="list-style-type: none"> - Solubility in water: : Not available - Solubility in oils and fats: : Not available <p><u>Flammability:</u></p> <ul style="list-style-type: none"> - Flash point : 14. °C - Upper/lower flammability or explosive limits : 3.1 - 18.1 % Volume 25°C - Autoignition temperature : 426. °C <p><u>Explosive properties:</u> Vapours can form explosive mixtures with air and are able to flame up or explode in presence of an ignition source.</p> <p><u>Oxidizing properties:</u> Not classified as oxidizing product.</p>
-----	---

9.2	<p>OTHER INFORMATION:</p> <ul style="list-style-type: none"> - Solids : 10.8 % Weight - VOC (supply) : 89.2 % Weight - VOC (supply) : 736.6 g/l <p>The values indicated do not always coincide with product specifications. The data for the product specifications can be found in the technical data sheet of the same. For additional information concerning physical and chemical properties related to safety and environment, see sections 7 and 12.</p>
-----	--

SECTION 10 : STABILITY AND REACTIVITY

10.1	<p>REACTIVITY:</p> <p><u>Corrosivity to metals:</u> It is not corrosive to metals.</p> <p><u>Pyrophorical properties:</u> It is not pyrophoric.</p>
10.2	<p>CHEMICAL STABILITY:</p> <p>Stable under recommended storage and handling conditions.</p>
10.3	<p>POSSIBILITY OF HAZARDOUS REACTIONS:</p> <p>Possible dangerous reaction with oxidizing agents, acids, alkalis, peroxides.</p>
10.4	<p>CONDITIONS TO AVOID:</p> <p><u>Heat:</u> Keep away from sources of heat.</p> <p><u>Light:</u> If possible, avoid direct contact with sunlight.</p> <p><u>Air:</u> Not applicable.</p> <p><u>Humidity:</u> Avoid extreme humidity conditions.</p> <p><u>Pressure:</u> Not applicable.</p> <p><u>Shock:</u> Not applicable.</p>
10.5	<p>INCOMPATIBLE MATERIALS:</p> <p>Keep away from oxidizing agents, from strongly alkaline and strongly acid materials.</p>
10.6	<p>HAZARDOUS DECOMPOSITION PRODUCTS:</p> <p>As consequence of thermal decomposition, hazardous products may be produced: nitrogen oxides.</p>



DIMAFIX PEN
Code: EX014S0999



SECTION 11 : TOXICOLOGICAL INFORMATION

No experimental toxicological data on the preparation is available. The toxicological classification for these mixture has been carried out by using the conventional calculation method of the Regulation (EC) No. 1272/2008-605/2014 (CLP).

11.1 INFORMATION ON TOXICOLOGICAL EFFECTS:

ACUTE TOXICITY:

Dose and lethal concentrations for individual ingredients :	DL50 (OECD 401) mg/kg oral	DL50 (OECD 402) mg/kg cutaneous	CL50 (OECD 403) mg/m3.4h inhalation
Ethyl alcohol	10470. Rat	> 20000. Rabbit	> 20000. Rat
Isopropyl alcohol	5045. Rat	12800. Rabbit	> 72600. Rat
n-butyl acetate	10768. Rat	17600. Rabbit	> 23400. Rat

No observed adverse effect level

Not available

Lowest observed adverse effect level

Not available

INFORMATION ON LIKELY ROUTES OF EXPOSURE : Acute toxicity:

Routes of exposure	Acute toxicity	Cat.	Main effects, acute and/or delayed
<u>Inhalation:</u> Not classified	ATE > 20000 mg/m3	-	Not classified as a product with acute toxicity if inhaled (based on available data, the classification criteria are not met).
<u>Skin:</u> Not classified	ATE > 2000 mg/kg	-	Not classified as a product with acute toxicity in contact with skin (based on available data, the classification criteria are not met).
<u>Eyes:</u> Not classified	Not available	-	Not classified as a product with acute toxicity by eye contact (lack of data).
<u>Ingestion:</u> Not classified	ATE > 5000 mg/kg	-	Not classified as a product with acute toxicity if swallowed (based on available data, the classification criteria are not met).

CORROSION / IRRITATION / SENSITISATION :

Danger class	Target organs	Cat.	Main effects, acute and/or delayed
<u>Respiratory corrosion/irritation:</u> Not classified	-	-	Not classified as a product corrosive or irritant by inhalation (based on available data, the classification criteria are not met).
<u>Skin corrosion/irritation:</u> Not classified	-	-	Not classified as a product corrosive or irritant in contact with skin (based on available data, the classification criteria are not met).
<u>Serious eye damage/irritation:</u> 	Eyes 	Cat.2	IRRITANT: Causes serious eye irritation.
<u>Respiratory sensitisation:</u> Not classified	-	-	Not classified as a product sensitising by inhalation (based on available data, the classification criteria are not met).
<u>Skin sensitisation:</u> Not classified	-	-	Not classified as a product sensitising by skin contact (based on available data, the classification criteria are not met).

ASPIRATION HAZARD:

Danger class	Target organs	Cat.	Main effects, acute and/or delayed
<u>Aspiration hazard:</u> Not classified	-	-	Not classified as a product hazardous by aspiration (based on available data, the classification criteria are not met).

SPECIFIC TARGET ORGANS TOXICITY (STOT): Single exposure (SE) and/or Repeated exposure (RE):

Effects	SE/RE	Target organs	Cat.	Main effects, acute and/or delayed
<u>Neurological:</u> 	SE	CNS 	Cat.3	NARCOSIS: May cause drowsiness or dizziness if inhaled.



DIMAFIX PEN
Code: EX014S0999



CMR EFFECTS:

Carcinogenic effects: Is not considered as a carcinogenic product.
Genotoxicity: Is not considered as a mutagenic product.
Toxicity for reproduction: Do not harm the fetus developing.
Effects via lactation: Not classified as a hazardous product for children breast-fed.

DELAYED AND IMMEDIATE EFFECTS AS WELL AS CHRONIC EFFECTS FROM SHORT AND LONG-TERM EXPOSURE:

Routes of exposure: May be absorbed by inhalation of vapour, through the skin and by ingestion.
Short-term exposure: Exposure to solvent vapour concentrations in excess of the stated occupational exposure limit, may result in adverse health effects, such as mucous membrane and respiratory system irritation and adverse effects on kidneys, liver and central nervous system. Liquid splashes in the eyes may cause irritation and reversible damage. If swallowed, may cause irritation of the throat; other effects may be the same as described in the exposure to vapours.
Long-term or repeated exposure: Repeated or prolonged contact may cause removal of natural fat from the skin, resulting in non-allergic contact dermatitis and absorption through the skin.

INTERACTIVE EFFECTS:

Not available.

INFORMATION ABOUT TOXICOCINETICS, METABOLISM AND DISTRIBUTION:

Dermal absorption: Not available.
Basic toxicokinetics: Not available.

ADDITIONAL INFORMATION:

Not available.

SECTION 12 : ECOLOGICAL INFORMATION

No experimental ecotoxicological data on the preparation as such is available. The ecotoxicological classification for these mixture has been carried out by using the conventional calculation method of the Regulation (EC) No. 1272/2008-605/2014 (CLP).

12.1	TOXICITY:			
	Acute toxicity in aquatic environment for individual ingredients : Ethyl alcohol Isopropyl alcohol 1-vinyl-2-pyrrolidone-vinyl acetate polymer n-butyl acetate	CL50 (OECD 203) mg/L.96hours 14200. Fishes 9640. Fishes 18. Fishes	CE50 (OECD 202) mg/L.48hours 5012. Daphnia 13300. Daphnia > 1000. Daphnia 44. Daphnia	CE50 (OECD 201) mg/L.72hours 275. Algae > 1000. Algae 675. Algae
	No observed effect concentration Not available			
	Lowest observed effect concentration Not available			
12.2	PERSISTENCE AND DEGRADABILITY: Not available.			
	Aerobic biodegradation for individual ingredients : Ethyl alcohol Isopropyl alcohol 1-vinyl-2-pyrrolidone-vinyl acetate polymer n-butyl acetate	DQO mgO2/g 1990. 2396. 2204.	%DBO/DQO 5 days 14 days 28 days ~ 74. ~ 95. ~ 99. 1. ~ 80. ~ 82. ~ 83.	Biodegradability Easy Easy Not easy Easy
12.3	BIOACCUMULATIVE POTENTIAL: Not available.			
	Bioaccumulation for individual ingredients : Ethyl alcohol Isopropyl alcohol 1-vinyl-2-pyrrolidone-vinyl acetate polymer n-butyl acetate	logPow -0.310 0.0500 1.81	BCF L/kg 3.2 (calculated) 3.2 (calculated) 6.9 (calculated)	Potential No bioaccumulable No bioaccumulable No bioaccumulable No bioaccumulable
12.4	MOBILITY IN SOIL: Not available.			
12.5	RESULTS OF PBT AND VPV B ASSESSMENT: Annex XIII of Regulation (EC) no. 1907/2006: Does not contain substances that fulfill the PBT/vPvB criteria.			
12.6	OTHER ADVERSE EFFECTS: Ozone depletion potential: Not available. Photochemical ozone creation potential: Not available. Earth global warming potential: In case of fire or incineration liberates CO2. Endocrine disrupting potential: Not available.			

SECTION 13 : DISPOSAL CONSIDERATIONS

13.1 **WASTE TREATMENT METHODS:** Directive 2008/98/EC-Regulation (EU) no. 1357/2014:
Take all necessary measures to prevent the production of waste whenever possible. Analyse possible methods for revaluation or recycling. Do not discharge into drains or the environment, dispose of at an authorised waste collection point. Waste should be handled and disposed of in accordance with current local and national regulations. For exposure controls and personal protection measures, see section 8.



DIMAFIX PEN
Code: EX014S0999



Disposal of empty containers: Directive 94/62/EC~2005/20/EC, Decision 2000/532/EC~2014/955/EU:
Emptied containers and packaging should be disposed of in accordance with currently local and national regulations. The classification of packaging as hazardous waste will depend on the degree of emptying of the same, being the holder of the residue responsible for their classification, in accordance with Chapter 15 01 of Decision 2000/532/EC, and forwarding to the appropriate final destination. With contaminated containers and packaging, adopt the same measures as for the product in itself.

Procedures for neutralising or destroying the product:
Controlled incineration in special facilities for chemical waste, in accordance with local regulations.

SECTION 14 : TRANSPORT INFORMATION

14.1 **UN NUMBER:** 1263

14.2 **UN PROPER SHIPPING NAME:**
PAINT

14.3 **TRANSPORT HAZARD CLASS(ES) AND PACKING GROUP:**

(Special provision 640D)
VP<110 kPa50°C

**Transport by road (ADR 2015) and
Transport by rail (RID 2015):**

- Class: 3
- Packaging group: II
- Classification code: F1 (D/E)
- Tunnel restriction code:
- Transport category: 2 , max. ADR 1.1.3.6. 333 L
- Limited quantities: 5 L (see total exemptions ADR 3.4)
- Transport document: Consignment paper.
- Instructions in writing: ADR 5.4.3.4



Transport by sea (IMDG 37-14):

- Class: 3
- Packaging group: II
- Emergency Sheet (EmS): F-E,S_E
- First Aid Guide (MFAG): 310,313
- Marine pollutant: No.
- Transport document: Shipping Bill of lading.



Transport by air (ICAO/IATA 2015):

- Class: 3
- Packaging group: II
- Transport document: Air Bill of lading.



Transport by inland waterways (ADN):

Not available.

14.5 **ENVIRONMENTAL HAZARDS:**
Not applicable (not classified as hazardous for the environment).

14.6 **SPECIAL PRECAUTIONS FOR USER:**
Ensure that persons transporting the product know what to do in case of accident or spill. Always transport in closed containers that are in a vertical position and sure. Ensure adequate ventilation.

14.7 **TRANSPORT IN BULK ACCORDING TO ANNEX II OF MARPOL 73/78 AND THE IBC CODE:**
Not applicable.

SECTION 15 : REGULATORY INFORMATION

15.1 **EU SAFETY, HEALTH AND ENVIRONMENTAL REGULATIONS/LEGISLATION SPECIFIC:**
The regulations applicable to this product generally are listed throughout this material safety data sheet.

Restrictions on manufacture, placing on market and use: See section 1.2

Control of the risks inherent in major accidents (Seveso III): See section 7.2

Tactile warning of danger: If the product is intended for the general public, is mandatory a tactile warning of danger. The technical specifications for tactile warning devices shall conform with EN ISO standard 11683 relating to 'Packaging - Tactile warnings of danger - Requirements.'

Child safety protection: Not applicable (the classification criteria are not met).

OTHER REGULATIONS:

Not available

15.2 **CHEMICAL SAFETY ASSESSMENT:**
For this mixture has not been carried out a chemical safety assessment.



DIMAFIX PEN
Code: EX014S0999



SECTION 16 : OTHER INFORMATION

- 16.1 [TEXT OF THE PHRASES AND NOTES REFERENCED IN SECTIONS 2 AND/OR 3:](#)
[Hazard statements according the Regulation \(EC\) No. 1272/2008-605/2014 \(CLP\), Annex III:](#)
 H225 Highly flammable liquid and vapour. H226 Flammable liquid and vapour. H319 Causes serious eye irritation. H336 May cause drowsiness or dizziness. H413 May cause long lasting harmful effects to aquatic life. EUH066 Repeated exposure may cause skin dryness or cracking.
- [ADVICES ON ANY TRAINING APPROPRIATE FOR WORKERS:](#)
 It is recommended for all staff that will handle this product to carry out a basic training in occupational risk and prevention, in order to provide understanding and interpretation of material safety data sheets and labelling of products as well.
- [MAIN LITERATURE REFERENCES AND SOURCES FOR DATA:](#)
- European Chemicals Agency: ECHA, <http://echa.europa.eu/>
 - Access to European Union Law, <http://eur-lex.europa.eu/>
 - Industrial Solvents Handbook, Ibert Mellan (Noyes Data Co., 1970).
 - Threshold Limit Values, (AGCIH, 2014).
 - European agreement on the international carriage of dangerous goods by road, (ADR 2015).
 - International Maritime Dangerous Goods Code IMDG including Amendment 37-14 (IMO, 2014).
- [ABBREVIATIONS AND ACRONYMS:](#)
 List of abbreviations and acronyms that can be used (but not necessarily used) in this material safety data sheet:
- REACH: Regulation concerning the Registration, Evaluation, Authorisation and Restriction of Chemicals.
 - DSD: Dangerous Substances Directive.
 - DPD: Dangerous Preparations Directive.
 - GHS: Globally Harmonized System of Classification and Labelling of Chemicals of the United Nations.
 - CLP: European regulation on Classification, Labelling and Packaging of substances and chemical mixtures.
 - EINECS: European Inventory of Existing Commercial Chemical Substances.
 - ELINCS: European List of Notified Chemical Substances.
 - CAS: Chemical Abstracts Service (Division of the American Chemical Society).
 - UVCB: Substances of Unknown or Variable composition, complex reaction products or biological materials).
 - SVHC: Substances of Very High Concern.
 - PBT: Persistent, bioaccumulable and toxic substances.
 - vPvB: Very persistent and very bioaccumulable substances.
 - VOC: Volatile Organic Compounds.
 - DNEL: Derived No-Effect Level (REACH).
 - PNEC: Predicted No-Effect Concentration (REACH).
 - LD50: Letal dose, 50 percent.
 - LC50: Letal concentration, 50 percent.
 - UN: United Nations Organisation.
 - ADR: European agreement concerning the international carriage of dangerous goods by road.
 - RID: Regulations concerning the international transport of dangerous goods by rail.
 - IMDG: International Maritime code for Dangerous Goods.
 - IATA: International Air Transport Association.
 - ICAO: International Civil Aviation Organization.
- [MATERIAL SAFETY DATA SHEET REGULATIONS:](#)
 Material Safety Data Sheet in accordance with Article 31 of Regulation (EC) No. 1907/2006 (REACH) and Annex of Regulation (EU) No. 2015/830.
- [HISTORY:](#) [Date of compilation:](#)
 Version: 1 13/09/2016

The information of this Material Safety Data Sheet, is based on the present state of knowledge and on current UE and national laws, as the users' working conditions are beyond our knowledge and control. The product is not to be used for other purposes than those specified, without first obtaining written handling instruction. It is always the responsibility of the user to take all necessary steps in order to fulfil the demand laid down in the local rules and legislation. The information in this Material Safety Data Sheet is meant as a description of the safety requirements of the product and it is not to be considered as a guarantee of the product's properties.